





































ISSUE	DATE	AMENDMENTS
4	16/09/13	GENERAL PRODUCTION UPDATE - WDA
5	13/02/14	REGEN OHP ADDED - WDA
6	06/05/14	MAINS INLET PANEL EARTH ADDED - WDA
7	09/07/14	WIRE NUMBERING CORRECTED - WDA
8	10/11/14	NEUTRALS RE-ARRANGED TO HELP PRODUCTION - WDA

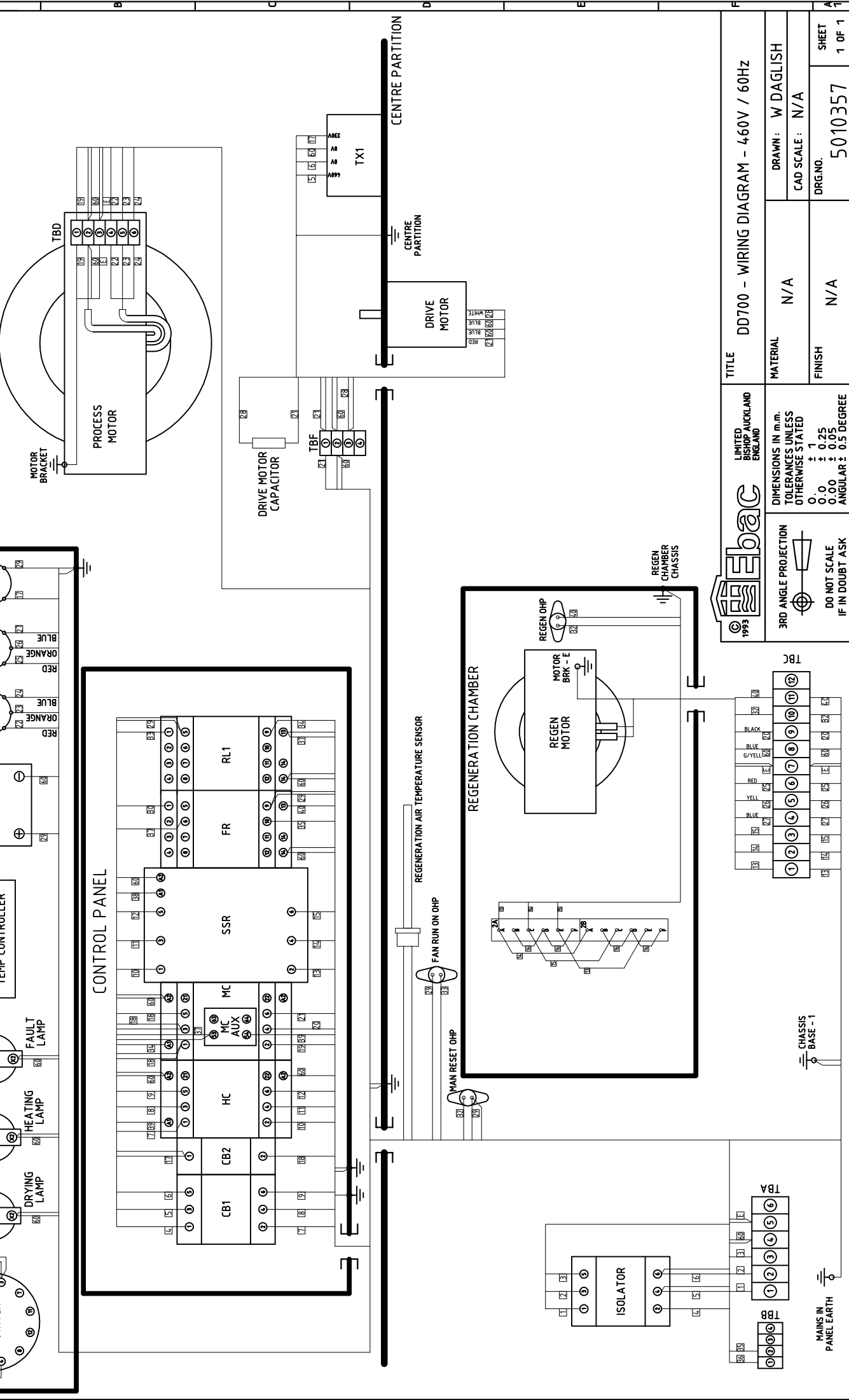

TITLE	MATERIAL	FINISH	DRG.NO.	SHEET
DD700 - WIRING DIAGRAM - 460V / 60HZ	N/A	N/A	5010357	1 OF 1
LIMITED BISHOP AUCKLAND ENGLAND		DRAWN: W DAGLISH		SHEET 1 OF 1
DIMENSIONS IN m.m. TOLERANCES UNLESS OTHERWISE STATED ± 1 0.00 ± 0.25 0.00 ± 0.05 ANGULAR ± 0.5 DEGREE		CAD SCALE: N/A		

3RD ANGLE PROJECTION	DO NOT SCALE IF IN DOUBT ASK

© 1993

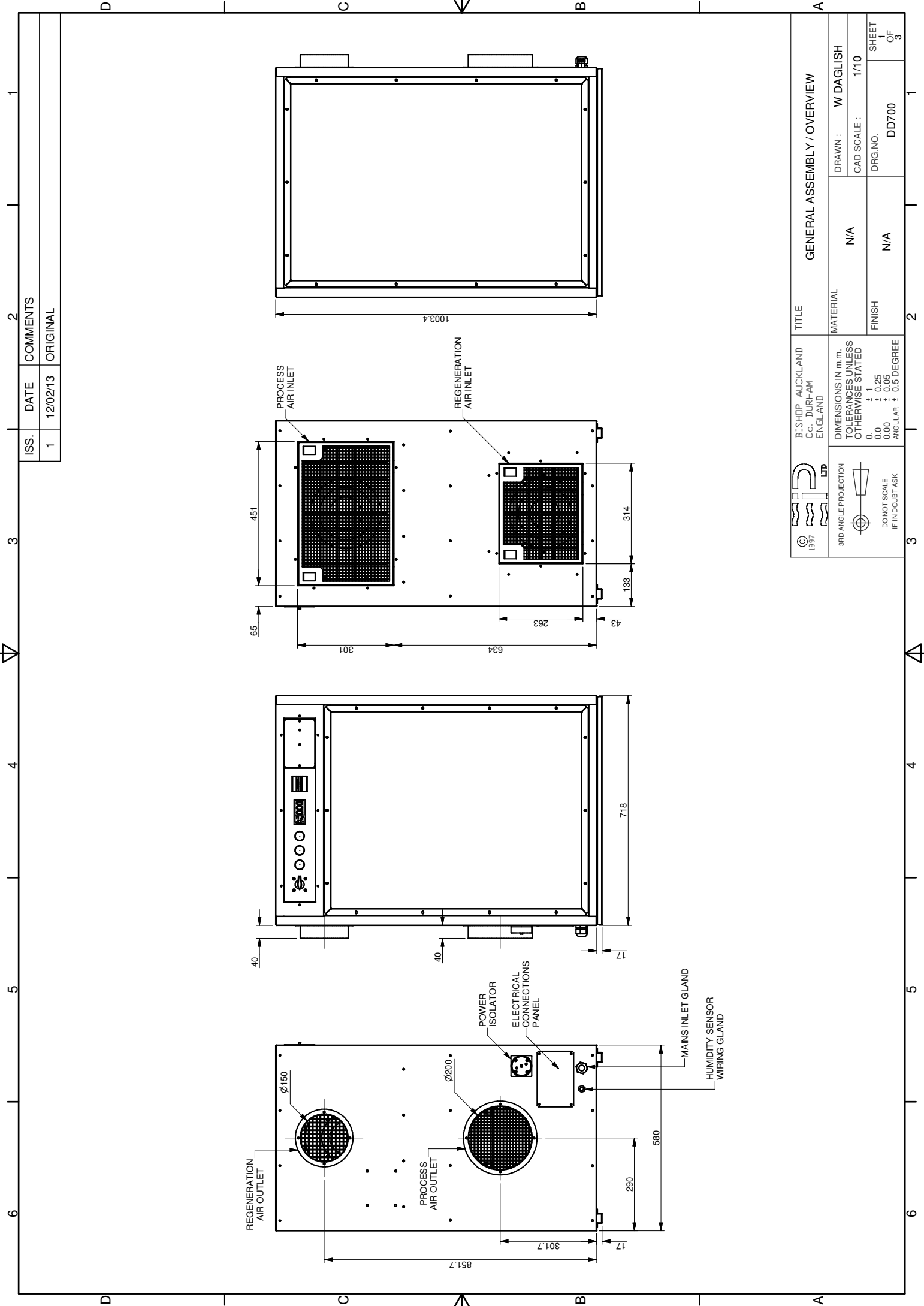

ISS.	DATE	COMMENTS
1	12/02/13	ORIGINAL

GENERAL ASSEMBLY / OVERVIEW	
TITLE	BISHOP AUCKLAND Co. DURHAM ENGLAND
MATERIAL	N/A
FINISH	N/A
DRAWN :	W DAGLISH
CAD SCALE :	1/10
DRG.NO.	DD700
SHEET	1
OF	3

© 1997  
 3RD ANGLE PROJECTION  
 DIMENSIONS IN m.m.  
 TOLERANCES UNLESS OTHERWISE STATED  
 0 ± 1  
 0.0 ± 0.25  
 0.00 ± 0.05  
 ANGULAR ± 0.5 DEGREE  
 DO NOT SCALE  
 IF IN DOUBT ASK

ISS.	DATE	COMMENTS
1	12/02/13	ORIGINAL

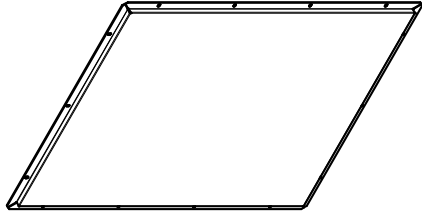
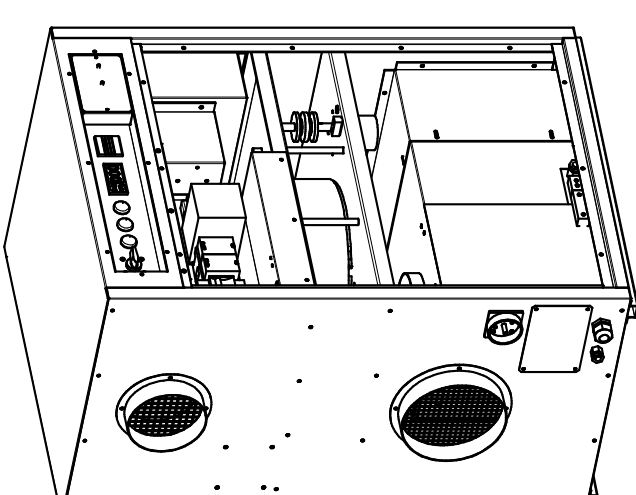
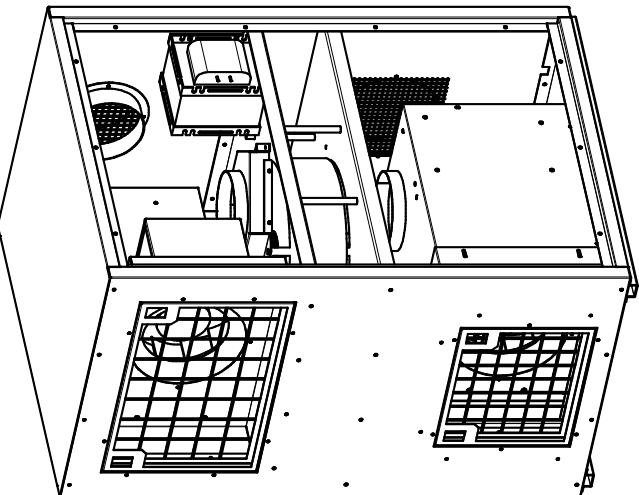
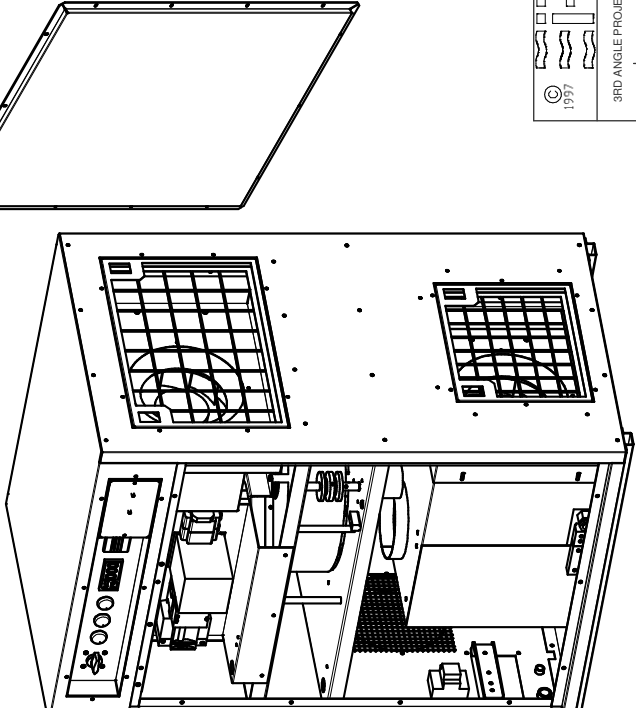
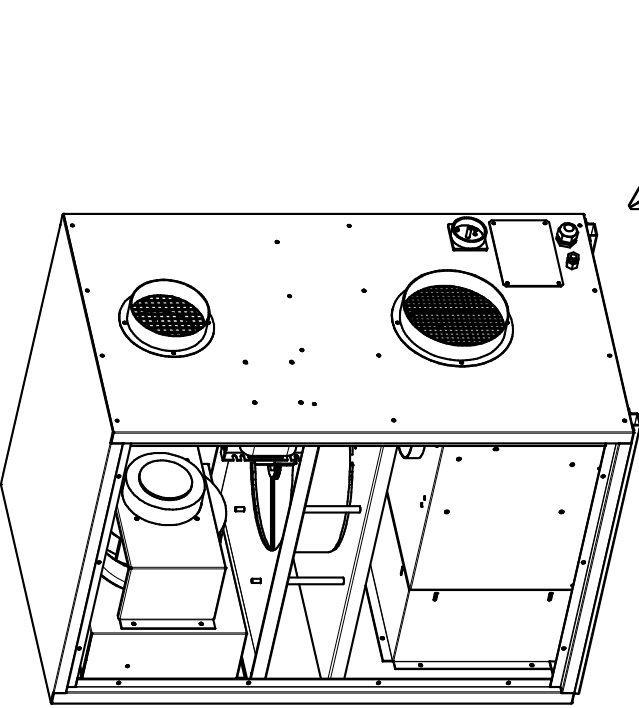
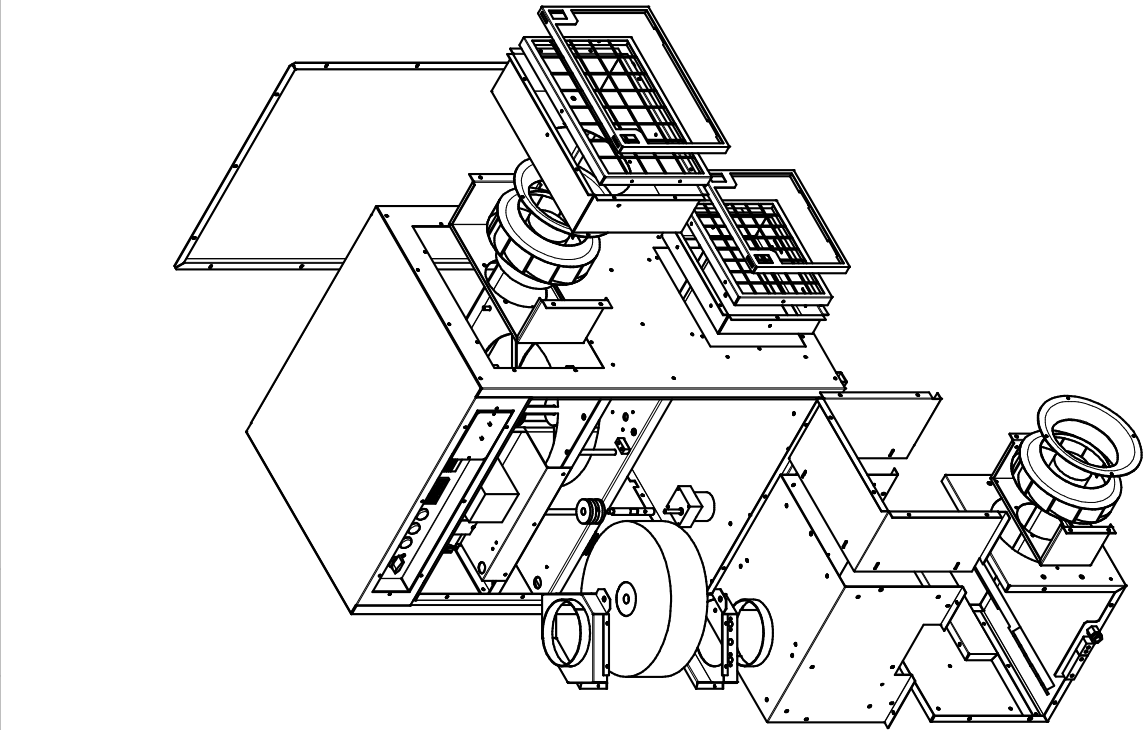

BISHOP AUCKLAND Co. DURHAM ENGLAND		GENERAL ASSEMBLY / OVERVIEW	
DIMENSIONS IN m.m. TOLERANCES UNLESS OTHERWISE STATED		MATERIAL	N/A
0	+ 1	FINISH	N/A
0.0	+ 0.25	DRG.NO.	DD700
0.00	+ 0.05	CAD SCALE:	1/10
ANGULAR	+ 0.5 DEGREE	DRAWN :	W DAGLISH
3RD ANGLE PROJECTION		SHEET	
DO NOT SCALE IF IN DOUBT ASK		1 OF 3	

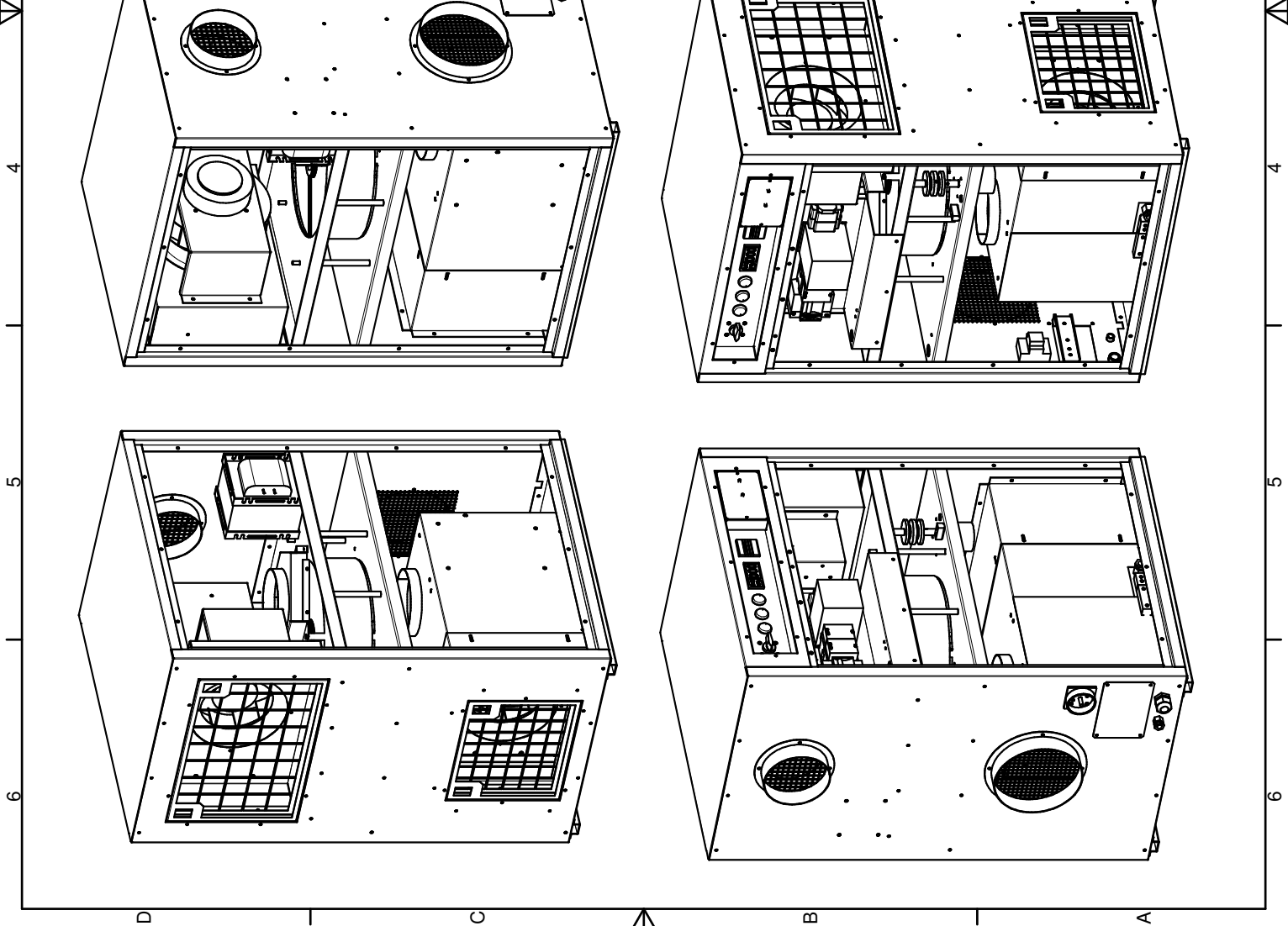

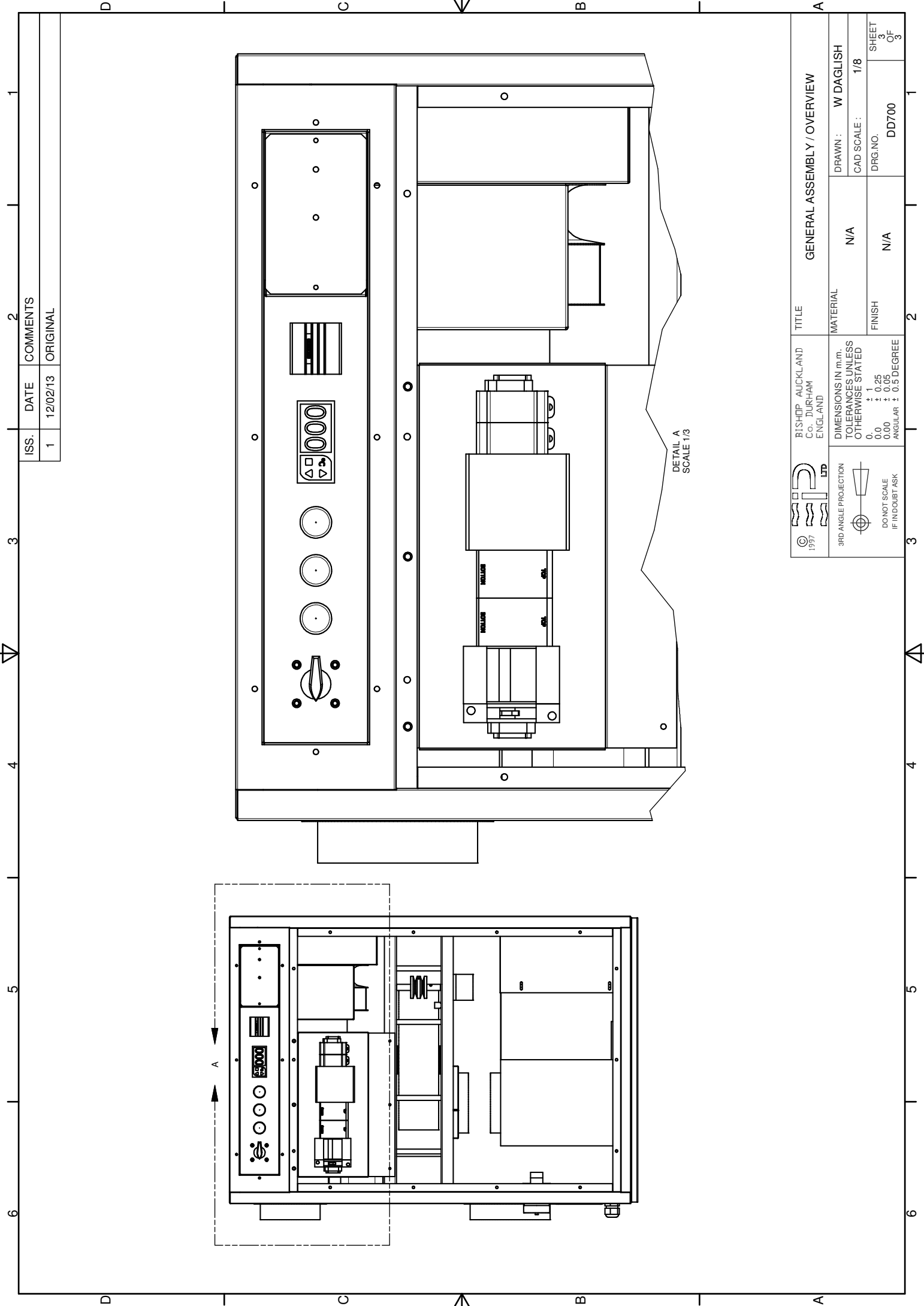

ISS.	DATE	COMMENTS
1	12/02/13	ORIGINAL

BISHOP AUCKLAND Co. DURHAM ENGLAND		GENERAL ASSEMBLY / OVERVIEW	
 3RD ANGLE PROJECTION DO NOT SCALE IF IN DOUBT ASK	DIMENSIONS IN m.m. TOLERANCES UNLESS OTHERWISE STATED	MATERIAL	DRAWN : W DAGLISH
	0 ± 1 0.0 ± 0.25 0.00 ± 0.05 ANGULAR ± 0.5 DEGREE	N/A	CAD SCALE : 1/8
		FINISH	DRG.NO. DD700
			SHEET 1 OF 3

DETAIL A  
SCALE 1/3

ISSUE	DATE	AMENDMENTS
1	30/11/12	ORIGINAL
2	13/02/13	PROTOTYPE ISSUES CORRECTED - WDA
3	13/03/13	PILOT BUILD ISSUES INCORPORATED - WDA
4	13/02/14	REGEN OHP ADDED - WDA
5	28/04/14	OHP'S CORRECTED - WDA

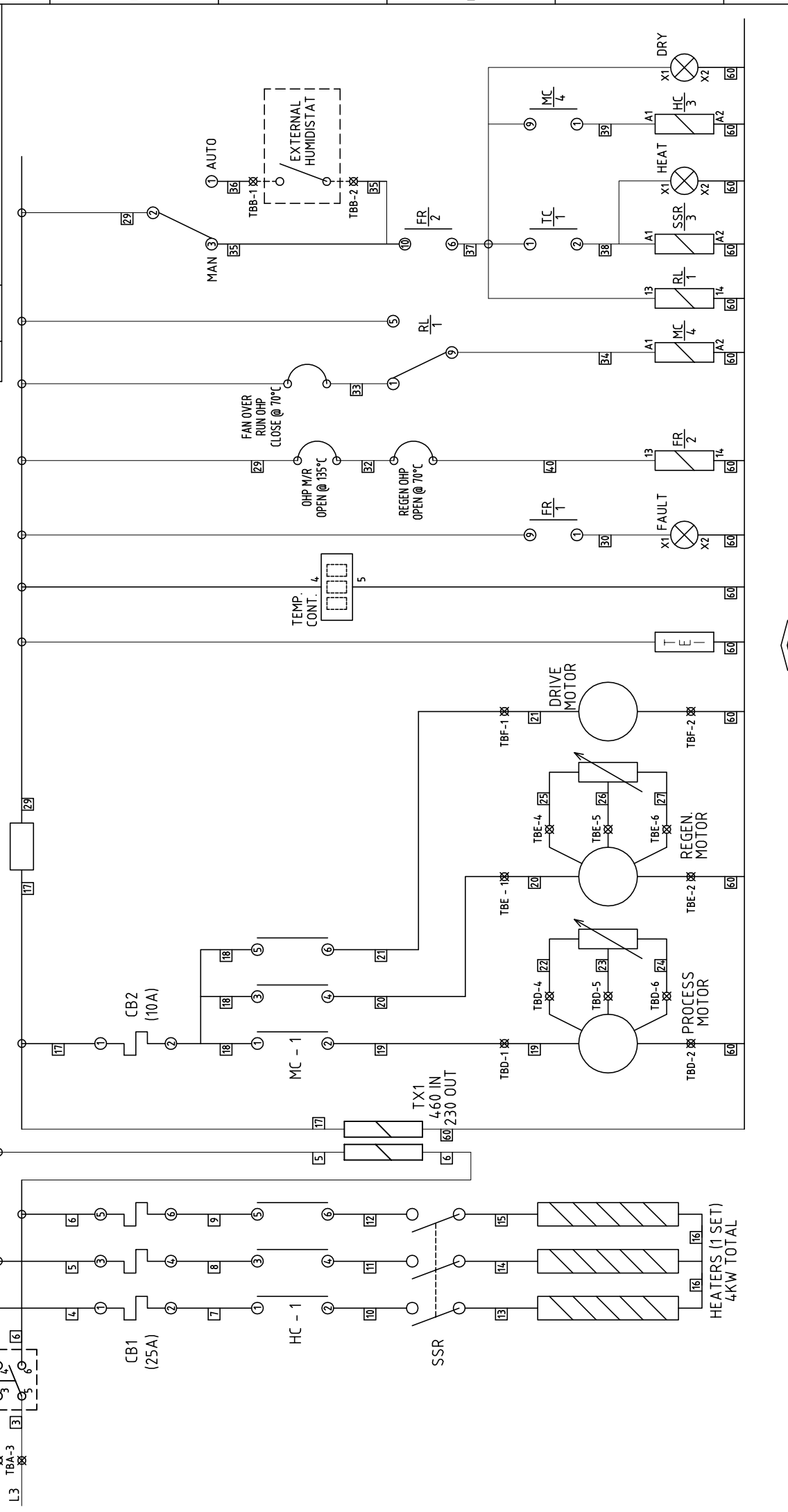

**1993 ebec**  
 LIMITED  
 BISHOP AUCKLAND  
 ENGLAND

**3RD ANGLE PROJECTION**

**TOLERANCES UNLESS OTHERWISE STATED**

DIMENSIONS IN mm	± 1
0.0	± 0.25
0.00	± 0.05
ANGULAR	± 0.5 DEGREE

**DO NOT SCALE  
IF IN DOUBT ASK**

TITLE	DD700 - 460V/60Hz 3PH - WIRING SCHEMATIC
MATERIAL	N/A
FINISH	N/A
DRAWN	W DAGLISH
CAD SCALE	N/A
DRG.NO.	5020357
SHEET	1 OF 1

ISSUE	DATE	AMENDMENTS
7	09/07/14	WIRE NUMBERING CORRECTED - WDA
8	10/11/14	NEUTRALS RE-ARRANGED TO HELP PRODUCTION - WDA
9	01/05/15	CONTROL BOX VIEW CHANGED - WDA
10	12/05/15	CONTROL BOX VIEW CHANGED - WDA
11	06/11/15	REGEN FAN T/B VIEW UPDATED - WDA

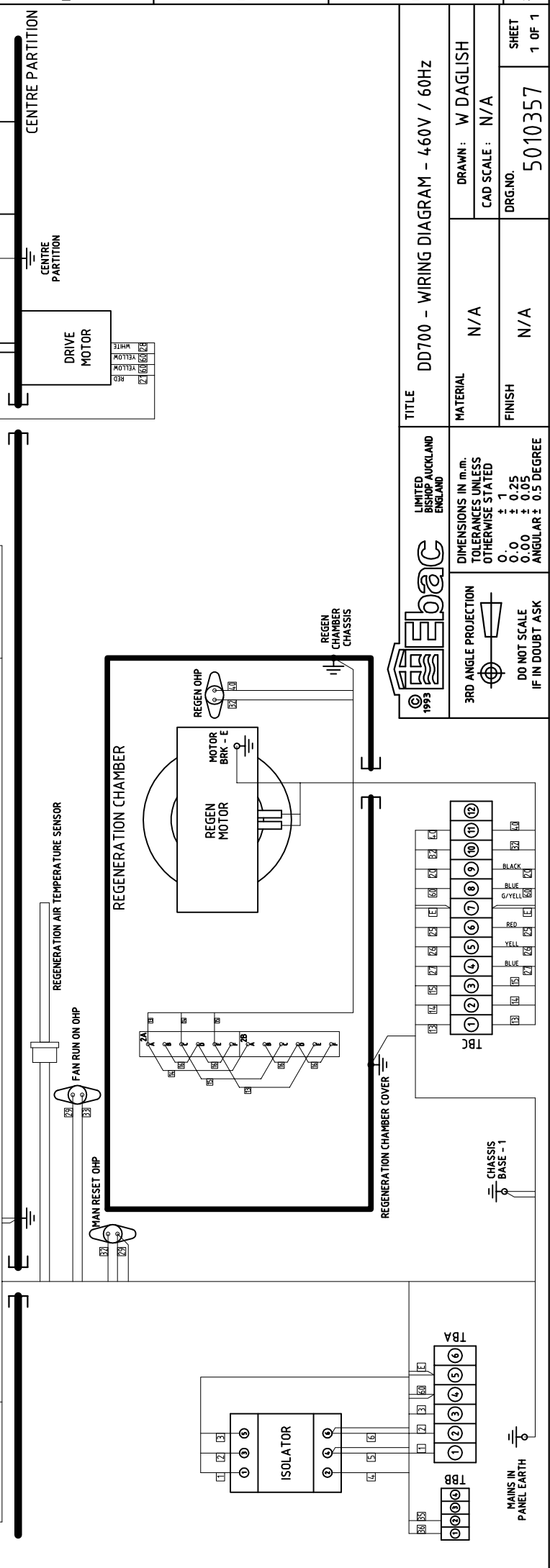
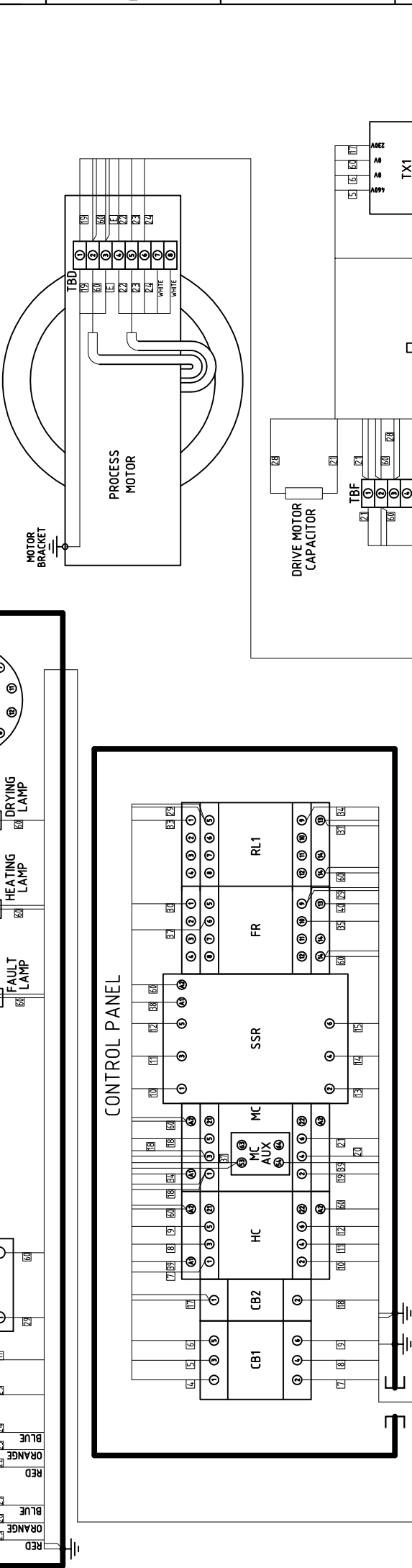
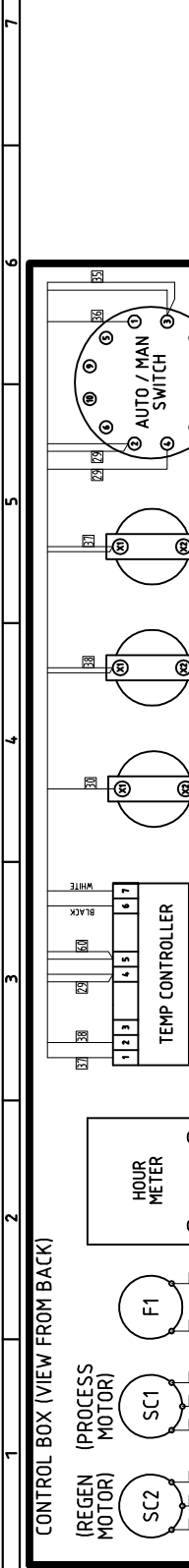

		<b>TITLE</b> DD700 - WIRING DIAGRAM - 460V / 60Hz	
LIMITED BUSHP, AUCKLAND ENGLAND		<b>MATERIAL</b> N/A	
DIMENSIONS IN m.m. TOLERANCES UNLESS OTHERWISE STATED ± 1 0.00 ± 0.25 0.00 ± 0.05 ANGULAR ± 0.5 DEGREE		<b>DRAWN:</b> W DAGLISH <b>CAD SCALE:</b> N/A	
3RD ANGLE PROJECTION DO NOT SCALE IF IN DOUBT ASK		<b>FINISH</b> N/A	
		<b>DRG.NO.</b> 5010357	
		<b>SHEET</b> 1 OF 1	

ISSUE	DATE	AMENDMENTS
1	26/02/16	ORIGINAL
2	23/03/16	DIGITAL STAT CORRECTED - WDA

**HUMIDISTAT 3035157**

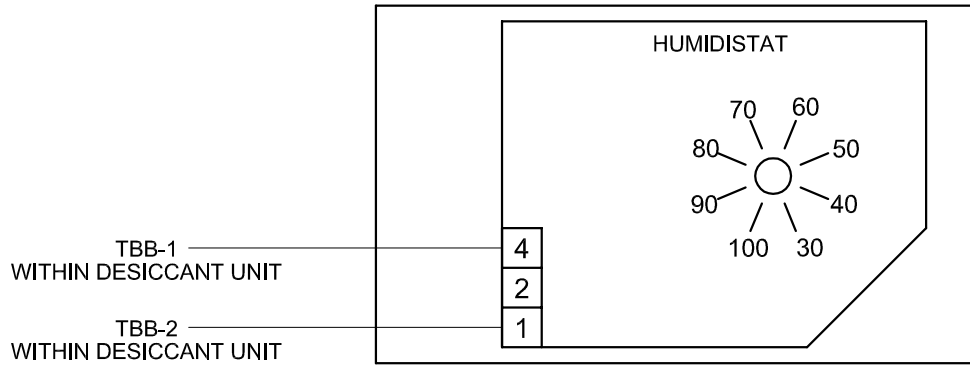

FROM	TERM.	TO	TERM.
H/STAT - 1	PLAIN	TBB-1	SOLDER
H/STAT - 4	PLAIN	TBB-2	SOLDER

- HUMIDISTAT 3035159 - 230V (INTERNAL SENSOR)
- HUMIDISTAT 3035160 - 115V (INTERNAL SENSOR)
- HUMIDISTAT 3035161 - 230V (EXTERNAL SENSOR)
- HUMIDISTAT 3035162 - 115V (EXTERNAL SENSOR)

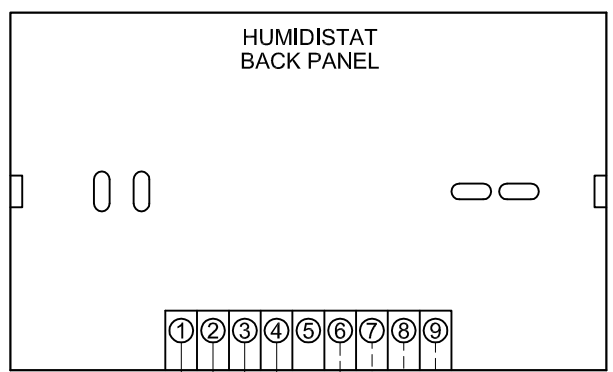

**NOTE**  
ON ALL VERSIONS OF THIS HUMIDISTAT DIP SWITCH 3 MUST BE IN THE 'ON' POSITION. THE DIP SWITCH PANEL IS LOCATED IN THE TOP LEFT CORNER WITHIN THE FRONT PANEL OF THE HUMIDISTAT.

HUMIDISTAT SENSOR  
(3035161 / 3035162 ONLY)

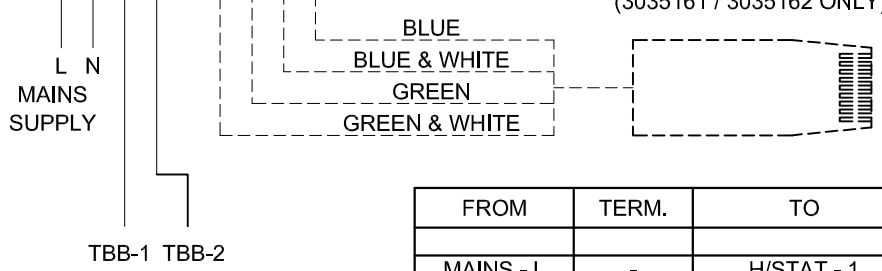

FROM	TERM.	TO	TERM.
MAINS - L	-	H/STAT - 1	PLAIN
MAINS - N	-	H/STAT - 2	PLAIN
H/STAT - 3	PLAIN	TBB-1	SOLDER
H/STAT - 4	PLAIN	TBB-2	SOLDER
H/STAT - 6	PLAIN	SENSOR-GR/WH	-
H/STAT - 7	PLAIN	SENSOR-GR	-
H/STAT - 8	PLAIN	PLUG - BL/WH	-
H/STAT - 9	PLAIN	PLUG - BL	-

© 1993 **Ebac** LIMITED BISHOP AUCKLAND ENGLAND

TITLE **DESICCANT - REMOTE H/STAT WIRING**

3RD ANGLE PROJECTION  
  
 DO NOT SCALE IF IN DOUBT ASK

DIMENSIONS IN m.m.  
TOLERANCES UNLESS OTHERWISE STATED  
 O. ± 1  
 O.O ± 0.25  
 O.OO ± 0.05  
 ANGULAR ± 0.5 DEGREE

MATERIAL **N/A**  
 FINISH **N/A**

DRAWN: W. DAGLISH  
 CAD SCALE: N/A  
 DRG.NO. **5010320**  
 SHEET 1 OF 1

